

BIOCIPPATORE CON MOTORE A SCOPPIO

CIP 120-B

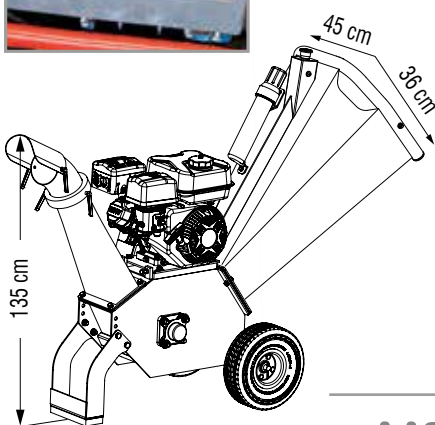

POWERED by
Loncin



L_{WA}
112 dB

L'apparecchiatura è conforme ai requisiti richiesti dalla direttiva 2000/14/CE per la limitazione del rumore ambientale.

The equipment complies with the requirements of Directive 2000/14/EC for the limitation of environmental noise.

COMBUSTION ENGINE BIO-SHREDDER

HOLZHÄCKSLER MIT VERBRENNUNGSMOTOR

BIOTRITURADORA CON MOTOR DE GASOLINA

BIO-BROYEUR À MOTEUR À EXPLOSION



MOD				
mod.	cod.	HP	kg	cm
CIP 120-B	1003991	LONCIN 420 cc 15 HP	212	85×205×135

MOD				
mod.	cm	rpm/min	nr	nr
CIP 120-B	12	2800	2	1

Di serie	Standard equipment	Serienmässig	De serie	De série
<ul style="list-style-type: none"> • Motore a scoppio con avviamento manuale (a richiesta con avviamento elettrico) • Sistema di taglio professionale con lame in acciaio di altissima qualità • Ruote 16×8.0-7 tubeless • Setaccio di raffinazione regolabile • Scarico orientabile a 360° • Controlame a 4 taglienti riposizionabili • Trasmissione a doppia cinghia trapezoidale • Protezioni antinfortunistiche conformi alla normativa CE 	<ul style="list-style-type: none"> • Combustion engine with manual start (electric start on request) • Professional cutting system with high-quality steel blades • 16×8.0-7 tubeless wheels • Adjustable refining sieve • 360° adjustable discharge • Counter-blades with 4 repositionable cutting edges • Double V-belt drive • Protective equipment as per EC safety rules 	<ul style="list-style-type: none"> • Verbrennungsmotor mit Handstart (Elektrostart auf Anfrage) • Professionelles Schneidsystem mit hochwertigen Stahlmessern • Schlauchlose Räder 16×8.0-7 • Verstellbares Feinsieb • 360° schwenkbarer Auswurf • Gegenmesser mit 4 verstellbaren Schneidkanten • Doppelter Keilriemenantrieb • Unfallschutz nach EU-Vorschriften 	<ul style="list-style-type: none"> • Motor de gasolina con arranque manual (arranque eléctrico bajo pedido) • Sistema de corte profesional con cuchillas de acero de alta calidad • Ruedas sin cámara 16×8.0-7 • Criba de afinado ajustable • Escape orientable 360 • Contracuchillas con 4 filos reposicionables • Doble transmisión por correa trapezoidal • Protecciones de seguridad de acuerdo con la norma CE 	<ul style="list-style-type: none"> • Moteur à explosion avec démarrage manuel (démarrage électrique sur demande) • Système de coupe professionnel avec des lames en acier de très haute qualité • Roues sans chambre à air 16×8.0-7 • Tamis d'affinage réglable • Décharge orientable à 360° • Contre-lames à 4 tranchants repositionnables • Entraînement par double courroie trapézoïdale • Protections contre les accidents conformes aux normes CE