

ZM 42

- ✓ SUPER PROFESSIONAL
- ✓ DOUBLE CUT BLADE
- ✓ 42 MM CUTTING DIAMETER
- ✓ POWER MAX 800 W
- ✓ BRUSHLESS MOTOR



ZM[®]42

Li-Ion BATTERY
RECHARGEABLE

2x



Valigetta completa

- Forbice elettronica
- 2 batterie
- Carica batteria
- Utensili per manutenzione
- Manuale istruzioni

Complete case

- Electronic pruning shear
- 2 batteries
- Battery charger
- Maintenance tools
- Instruction manual

Maletín completo

- Tijera
- 2 baterías
- Cargador de batería
- Herramientas de mantenimiento
- Manual de instrucciones

Dati tecnici

Technical data

Datos técnicos

ZM 42

| | | | |
|--------------------------------|---------------------------|---------------------------------------|--------------------------|
| Diametro di taglio massimo | Maximum cutting diameter | Diámetro máximo de corte | Ø 42 mm |
| Posizioni di apertura lama | Blade opening positions | Posiciones de apertura de la cuchilla | Settable (10-42 mm) |
| Peso (senza batteria) | Weight (without battery) | Peso (sin batería) | 910 gr |
| Taglio progressivo | Progressive cut | Corte progresivo | ✓ |
| Motore elettrico | Electric motor | Motor eléctrico | Brushless |
| Display LCD | Display LCD | Display LCD | ✓ |
| Batteria consigliata | Recommended battery | Batería recomendada | 18 V (21 V Max) - 2,5 Ah |
| Indicatore di carica batteria | Battery charge indicator | Indicador de carga de la batería | ✓ |
| N° di batterie incluse | No. of batteries included | No de baterías incluidas | 2 |
| Autonomia media della batteria | Average battery life | Autonomía media de la batería | 2~3 h |
| Tempo di ricarica batteria | Battery charging time | Tiempo de recarga de la batería | 1.5~2 h |

Valigetta completa
Complete case
Maletín completo

Cod. 2060835

Batteria 18 V (21 V Max) - 2,5 Ah
18 V (21 V Max) - 2,5 Ah battery
Batería 18 V (21 V Max) - 2,5 Ah



W
494 g

Cod. 5444406



Prolunga batteria Li-Ion 18V
18V Li-Ion battery extension
Extensión batería Li-Ion 18V



A richiesta
On request
Bajo pedido

Cod. 3250314

Asta telescopica per forbice ZM 42
Telescopic rod for pruning shear ZM 42
Pértiga telescópica cm para Tijera ZM 42



W
2,3 kg

A richiesta
On request
Bajo pedido

Cod. 3250500

ZM 42

ZM 42

- ✓ **SUPER PROFESSIONAL**
- ✓ **DOUBLE CUT BLADE**
- ✓ **42 MM CUTTING DIAMETER**
- ✓ **POWER MAX 800 W**
- ✓ **BRUSHLESS MOTOR**



ZM[®]42

Li-Ion BATTERY RECHARGEABLE

2x



Mallette complet

- Sécateur électronique
- 2 batteries
- Chargeur
- Outils d'entretien
- Manuel d'emploi

Complete case

- Electronic pruning shear
- 2 batteries
- Battery charger
- Maintenance tools
- Instruction manual

Kompletter Koffer

- Elektronische Schere
- 2 Akkus
- Ladegerät
- Wartungswerkzeuge
- Bedienungsanleitung

Données techniques

Technical data

Technische Daten

ZM 35

| | | | |
|-------------------------------------|---------------------------|---------------------------------|---------------------------------|
| Diamètre de coupe maximum | Maximum cutting diameter | Maximaler Schnittdurchmesser | Ø 42 mm |
| Positions d'ouverture de la lame | Blade opening positions | Öffnungspositionen der Klingen | Settable (10-42 mm) |
| Poids (sans batterie) | Weight (without battery) | Gewicht (ohne Akku) | 910 gr |
| Coupe progressive | Progressive cut | Progressiver Schnitt | ✓ |
| Moteur électrique | Electric motor | Elektromotor | Brushless |
| Affichage LCD | Display LCD | LCD Anzeige | ✓ |
| Batterie recommandée | Recommended battery | Empfohlener Akku | 18 V (21 V Max) - 2,5 Ah |
| Indicateur de charge de la batterie | Battery charge indicator | Akku-Ladeanzeige | ✓ |
| Nombre de piles incluses | No. of batteries included | Anzahl der enthaltenen Akkus | 2 |
| Autonomie moyenne de la batterie | Average battery life | Durchschnittliche Akku Laufzeit | 2~3 h |
| Temps de recharge de la batterie | Battery charging time | Akkuladezeit | 1.5~2 h |

Mallette complet
 Complete case
 Kompletter Koffer

Cod. 2060835

Batterie 18 V (21 V Max) - 2,5 Ah
 18 V (21 V Max) - 2,5 Ah battery
 18 V (21 V Max) - 2,5 Ah Akku



 494 g

Cod. 5444406

Extension de la batterie Li-Ion 18V
 18V Li-Ion battery extension
 Verlängerungskabel für Akku 18V Li-Ion



Sur demande
 On request
 Auf Anfrage

Cod. 3250314

Tige télescopique pour sécateur ZM 35
 Telescopic rod for pruning shear ZM 35
 Teleskopstange für Schere ZM 35

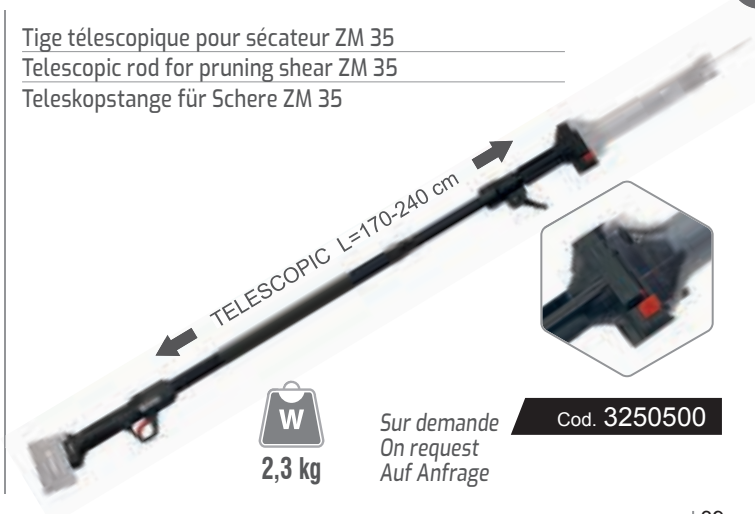

 2,3 kg

Sur demande
 On request
 Auf Anfrage

Cod. 3250500

